

Welded, Stainless Steel Double-Ended Shear Beam Load Cell

FEATURES

- Rated capacities of 1000 to 100,000 pounds
- Stainless steel, welded seal construction
- Insensitive to side loads and bending moments
- High output—well suited to high deadload/low liveload applications
- Load cells have matched outputs for multi-cell systems
- Integral conduit adaptor
- Sensorgage™ sealed to IP67 standards
- Factory Mutual System Approved for Classes I, II, III; Divisions 1 and 2; Groups A through G.
- Non-incendive ratings (without barriers)
- **Optional**
 - Fully hermetically sealed version

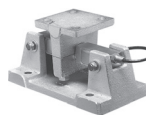

65016-TWA



65086



APPLICATIONS

- Hostile environments:
 - Food and beverage processing
 - Chemical and plastics processing
 - Pharmaceutical and biomedical processing
- Tank, bin, and silo weighing
- Batching, blending and mixing systems
- Level and inventory monitoring

DESCRIPTION

Model 65016-W is designed to be center-mounted with double-linked loading. This design provides free movement in all horizontal directions, virtually eliminating binding or friction points. The double Shear Beam design gives an excellent performance for high capacity loading.

The stainless-steel construction and IP67 rating make this load cell ideal for any environmental installation.

OUTLINE DIMENSIONS in inches

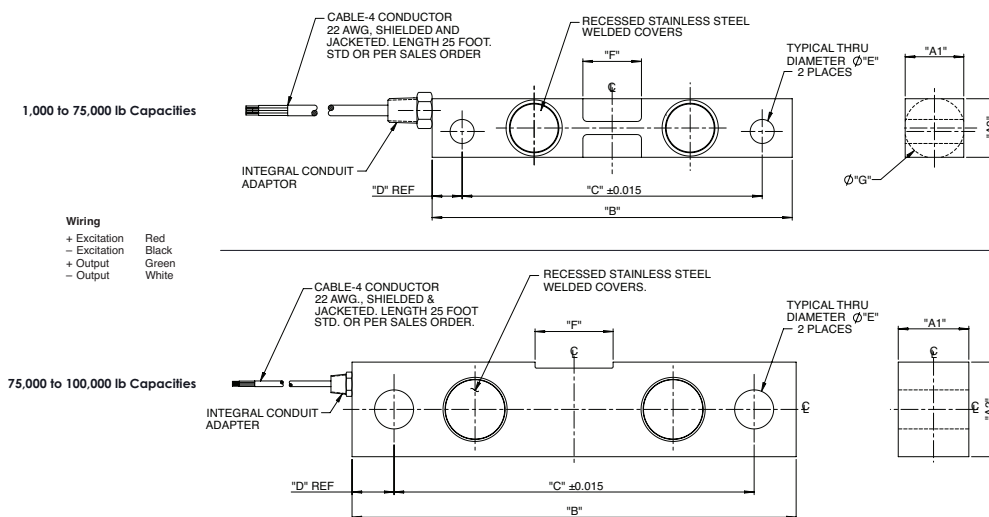

CAPACITY	A1	A2	B	C	D	E	F	G	THREAD	LOADING SURFACE
1k-5k	1.22	1.22	7.50	6.25	0.62	0.50	1.12	1.25	1/4-18NPT	Round
10k-25k	1.44	1.94	8.75	7.50	0.62	0.81	1.62	1.99	1/4-18NPT	Round
35k	1.44	2.44	8.75	7.50	0.62	0.81	1.62	2.50	1/4-18NPT	Round
50k-60k and 75k*	2.44	2.94	13.50	11.50	1.00	1.31	3.75	2.99	1/2-14NPT	Round
75k*-80k	2.44	2.94	13.50	11.50	1.00	1.31	3.25	-	1/2-14NPT	Square
100k	2.94	3.94	18.50	15.00	1.75	1.63	3.25	-	1/2-14NPT	Square

Capacities are in pounds.

* Only 75k capacity is possible in either round or square loading surface.

Welded, Stainless Steel Double-Ended Shear Beam Load Cell

SPECIFICATIONS		
PARAMETER	VALUE	UNIT
Rated capacity—R.C. (E_{max})	1k, 1.5k, 2.5k, 5k, 10k, 15k, 25k, 35k, 50k, 60k, 75k, 80k, 100k	lbs
NTEP/OIML accuracy class	Standard	
Maximum no. of intervals (n)	—	
Rated output—R.O.	3.0	mV/V
Rated output tolerance	0.25	±% mV/V
Zero balance	1.0	±% FSO
Non-linearity	0.07%	±% FSO
Hysteresis	0.07%	±% FSO
Non-repeatability	0.01	±% FSO
Creep error (20 minutes)	0.03	±% FSO
Temperature effect on zero	0.0015	±% FSO/°F
Temperature effect on output	0.0008	±% of load/°F
Compensated temperature range	14 to 104 (–10 to 40)	°F (°C)
Operating temperature range	0 to 150 (–18 to 65)	°F (°C)
Storage temperature range	–60 to 185 (–50 to 85)	°F (°C)
Sideload rejection ratio	500:1	
Safe sideload	100	% of R.C.
Maximum safe central overload	150	% of R.C.
Ultimate central overload	300	% of R.C.
Excitation, recommended	15	VDC or VAC RMS
Excitation, maximum	25	VDC or VAC RMS
Input impedance	686–714	Ω
Output impedance	699–707	Ω
Insulation resistance at 50 VDC	>1000	MΩ
Material	Stainless steel	
Environmental protection	IP67 IP68 welded seals, glass to metal seal	Standard Special

FSO— Full Scale Output

All specifications subject to change without notice.

CERTIFICATION MARKINGS

FM Approval markings (USA and Canada)
IS Class I, II, III, Division 1, Groups A, B, C, D, E, F and G;
NI Class I, Division 2, Groups A, B, C, and D,
DIP, Class II, III, Division 2, Groups F and G;
T4;
Ta = -25°C to +66°C